

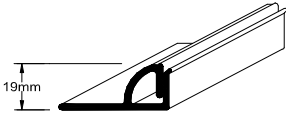
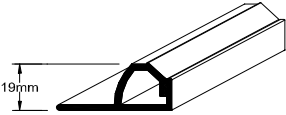
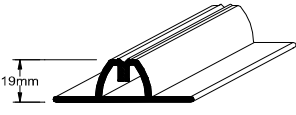
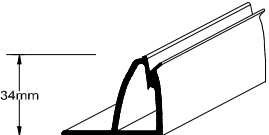
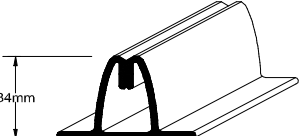
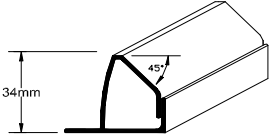
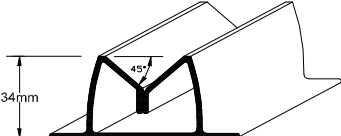

PRO-STRETCH TRACK

FIRE RATED PLASTIC EXTRUSION (3 M. / 10FT. LENGTHS NOMINAL*)

DIE #	DESCRIPTION	PROFILE	WEIGHT / CARTON	CTN. QTY. L. FT.
RS. 1968	3/4" PERIMETER 19		44 lbs.	200
RS. 1761	3/4" PERIMETER BEVEL 19		42 lbs	200
RS. 1762	3/4" MIDWALL 19		73 lbs	250
RS. 1291	1 3/8" PERIMETER 34		60 lbs.	240
RS. 1267	1 3/8" MIDWALL 34		50 lbs.	160
RS. 1414	1 3/8" PERIMETER BEVEL 34		45 lbs.	180
RS. 1298	1 3/8" REVEAL 34 BEVEL MIDWALL		38 lbs.	80

Standard Carton Dimensions: 6"W x 6"H x 120"L

*Actual length of Extrusion: 118 1/8"

US#1